



RIVERS LOCKING SYSTEMS (AUSTRALIA) PTY LTD

NEW SOUTH WALES:	50 ORCHARDLEIGH ST, YENNORA NSW 2161	PHONE: (02) 9632 9777	FAX: (02) 9632 7477
VICTORIA:	71-73 MAFFRA ST, COOLAROO VICTORIA 3048	PHONE (03) 9302 3366	FAX: (03) 9302 3966
QUEENSLAND:	181-185 COBALT ST, CAROLE PARK QLD 4300	PHONE: (07) 3271 2877	FAX: (07) 3271 2284
SOUTH AUSTRALIA:	25 CIRCUIT COURT, HENDON SA 5014	PHONE: (08) 8445 9999	FAX: (08) 8347 2073

RIVERS 410/420 FOUR POINT LOCK - OPEN IN DOOR

1. ***Check contents of box against packing list to ensure all components have been supplied.***
2. ***Mark centreline of Lock across inside of door at desired height (nominally 1100mm from floor to centreline of Handle). (Fig. 1)***
3. ***Remove cover from Lock Body.***
4. ***Position Lock onto door at pre-determined height & such that the clearance between Lock Body & edge of door is approx. 5-10mm at opening side & 20-25mm at hinge side. (Fig. 1 & 2) Fix Lock to door using only three self-tapping screws or for Model 410 Locks (no Lock Cylinder required) use all self-tapping screws to fix Lock to door.***
5. ***This step only applies to Model 420 Locks. Mark four Cylinder Shield holes & Cylinder centre using the Lock Backing Plate as a template. (Fig. 3)***
6. ***This step only applies to Model 420 Locks. Remove Lock Body from door & drill four 10mm dia. holes through door, then counter bore each 15mm dia. x 25mm deep from the outside. Drill Lock Cylinder hole 32mm dia. (Fig. 4 & 5)***
7. ***Mount Lock Body to door using self-tapping screws provided. Note: Model 410 Locks (no Lock Cylinder required) are already fully mounted with all self-tapping screws at this point (refer to step 4).***
8. ***This step only applies to Model 420 Locks. Fit Cylinder Shield Assembly to door using screws provided. Fix through lock body. (Fig.7)***
9. ***This step only applies to Model 420 Locks. With the Locking Bars extended (i.e. locked position) & the key removed from the Cylinder, ensure that the Cam (that accepts the Cylinder Tail) is oriented such that the Cam Lobe points away from the back of the Cam Locking Bar. (Fig. 6 & 7). This step is critical for the Lock to function as intended.***
10. ***With door closed, activate the Locking Bars so that they are extended over the doorframe. Position the keepers over the locking bars & against the frame, ensuring that there is equal clearance around the bars. Tack them in position & then fully weld once satisfied with operation. (Fig. 7)***
11. ***This step only applies to Model 420 Locks. Fit outside Handle & Spindle to door using screws provided.***
12. ***At this point check the operation of the Cam Locking Bar. Ensure when the outside Lever Handle is moved upwards to the horizontal position, the Cam Locking Bar falls freely into the cut out in the Inner Cam Plate. (Fig. 6) If this does not happen try adding a small washer under the Cam Plate. (Fig. 7)***
13. ***Ensure correct Lock operation. Inside Handle must disengage Locking Bars at all times (for escape), while the outside Handle should not operate unless the Cylinder has been unlocked with the key.***
14. ***Replace Lock Body Cover.***
15. ***Ensure Lock operates smoothly & without resistance. Excessive force should not be required to activate lock. Inside Lever Handle must operate in a downward motion & allow escape at all times.***
16. ***Apply Rivers self-adhesive label to lock body.***

**PLEASE NOTE: RIVERS RESERVES THE RIGHT TO CHANGE SPECIFICATIONS WITHOUT NOTICE
RIVERS LOCKS SHOULD ONLY BE MOUNTED ONTO SOLID CORE DOORS**

410/420 FOUR POINT LOCK-OPEN IN DOOR

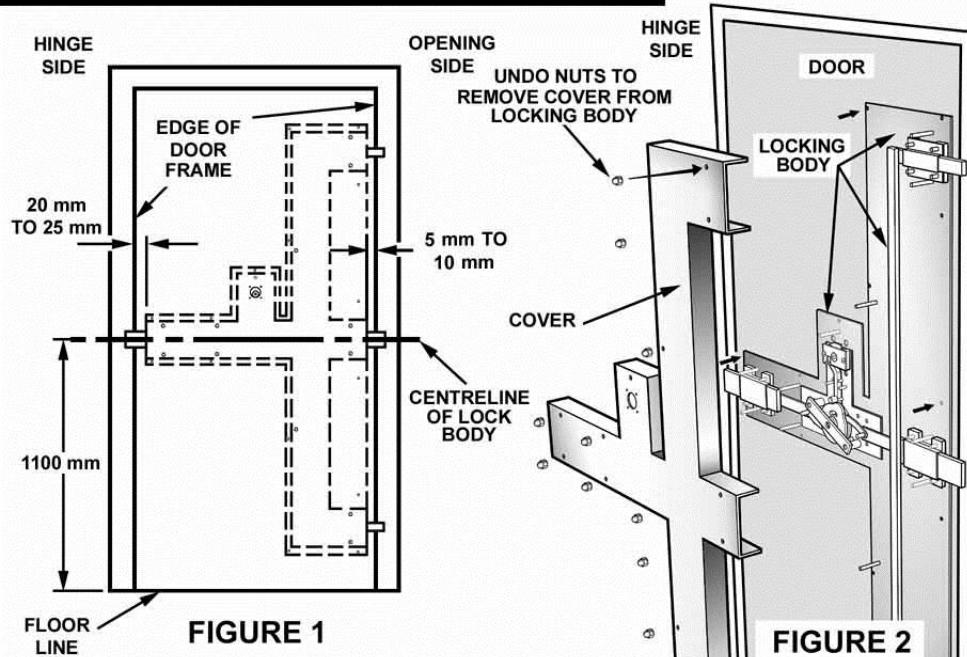

LOCKING BODY MOUNTS TO DOOR USING SELF-TAPPING SCREWS

WHEN CYLINDER MOUNTING HOLES ARE TO BE MARKED ONTO DOOR, USE ONLY 3 SELF-TAPPING SCREWS, TEMPORARILY, TO MOUNT LOCK TO DOOR OR, FOR LOCKS WITHOUT CYLINDERS, USE ALL SELF TAPPING SCREWS TO PERMANENTLY MOUNT LOCK TO DOOR

USING BACKING PLATE AS A TEMPLATE, MARK FOUR CYLINDER MOUNTING HOLES & CYLINDER CENTRE ON DOOR

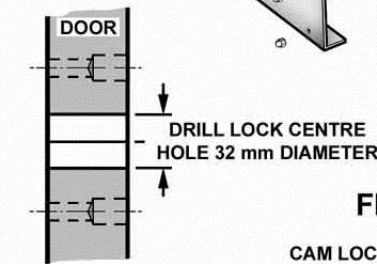
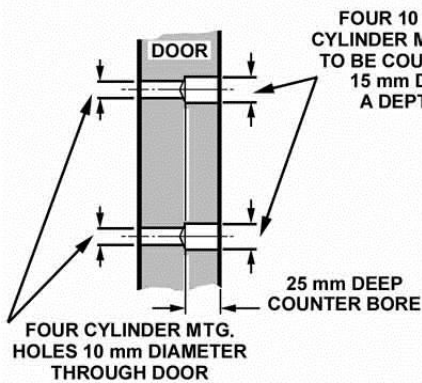
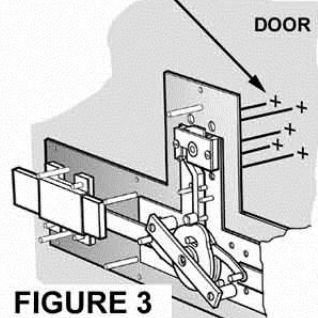

FIGURE 6

