



## RIVERS LOCKING SYSTEMS (AUSTRALIA) PTY LTD

NEW SOUTH WALES:	50 ORCHARDLEIGH ST, YENNORA NSW 2161	PHONE: (02) 9632 9777	FAX: (02) 9632 7477
VICTORIA:	71-73 MAFFRA ST, COOLAROO VICTORIA 3048	PHONE (03) 9302 3366	FAX: (03) 9302 3966
QUEENSLAND:	181-185 COBALT ST, CAROLE PARK QLD 4300	PHONE: (07) 3271 2877	FAX: (07) 3271 2284
SOUTH AUSTRALIA:	25 CIRCUIT COURT, HENDON SA 5014	PHONE: (08) 8445 9999	FAX: (08) 8347 2073

### **RIVERS 410/420 SEMAPHORE LOCK - OPEN IN DOOR**

1. **Check contents of box against packing list to ensure all components have been supplied.**
2. **Remove cover from Lock Body.**
3. **Position Lock onto door so that bottom of Lock is 5-10mm up from the bottom of the door & such that the edge of the Lock Body is as close as is practical to the opening edge of the active door leaf. (Fig. 1 & 2) Fix Model 420 Lock to door using only three self-tapping screws or for Model 410 Lock (no Lock Cylinder required) use all self-tapping screws to fix Lock to door.**
4. **This step only applies to Model 420 Locks. Mark four Cylinder Shield holes & Cylinder centre using the Lock Backing Plate as a template. (Fig. 3)**
5. **This step only applies to Model 420 Locks. Remove Lock Body from door & drill four 10mm dia. holes through door, then counter bore each 15mm dia. x 25mm deep from the outside. (Fig. 4) Drill Lock Cylinder hole 32mm dia. (Fig. 5)**
6. **Mount Lock Body to door using self-tapping screws provided. Note: Model 410 Locks (no Lock Cylinder required) are already fully mounted with all self-tapping screws at this point (refer to step 3).**
7. **This step only applies to Model 420 Locks. Fit Cylinder Shield Assembly to door using screws provided. Fix through lock body. (Fig. 7)**
8. **This step only applies to Model 420 Locks. With the Locking Bars extended (i.e. locked position) & the key removed from the Cylinder, ensure that the Cam (that accepts the Cylinder Tail) is oriented such that the Cam Lobe points away from the back of the Cam Locking Bar. (Fig. 6 & 7). The door will need to be in the open position to do this. This step is critical for the Lock to function as intended.**
9. **With door closed, activate the Locking Bars so that the lower bar touches on the flooring. Mark position of locking bar on floor. Use masonry drill to drill out floor to accept lower locking Bar.**
10. **With door closed, activate the Locking Bars so that the top bar extends over the frame at the head. Position the keeper supplied over the Locking Bar & against the frame, ensuring there is equal clearance around the bar. Weld in position. (Fig. 8)**
11. **With the door leaves closed & Lock in the locked position, the third & fourth Locking Arms should be lying over the secondary door leaf. Position the Receiving Cups provided over these Locking Bars. Ensure that the arms swing freely in & out of the Cups. Fix through secondary door leaf with screws & nuts supplied. (Fig. 9)**
12. **This step only applies to Model 420 Locks. Fit outside Handle & Spindle to door using screws provided.**
13. **At this point check the operation of the Cam Locking Bar. Ensure when the outside Lever Handle is moved upwards to the horizontal position, the Cam Locking Bar falls freely into the cut out in the Inner Cam Plate. (Fig. 6) If this does not happen try adding a small washer under the Cam Plate. (Fig. 7)**
14. **Ensure correct Lock operation. Inside Handle must disengage Locking Bars at all times (for escape), while the outside Handle should not operate unless the Cylinder has been unlocked with the key.**
15. **Replace Lock Body Cover.**
16. **Ensure Lock operates smoothly & without resistance. Excessive force should not be required to activate lock. Inside Lever Handle must operate in a downward motion & allow escape at all times.**
17. **Apply Rivers self-adhesive label to lock body.**

**PLEASE NOTE: RIVERS RESERVES THE RIGHT TO CHANGE SPECIFICATIONS WITHOUT NOTICE  
RIVERS LOCKS SHOULD ONLY BE MOUNTED ONTO SOLID CORE DOORS**

**410/420 SEMAPHORE LOCK-OPEN IN DOOR**

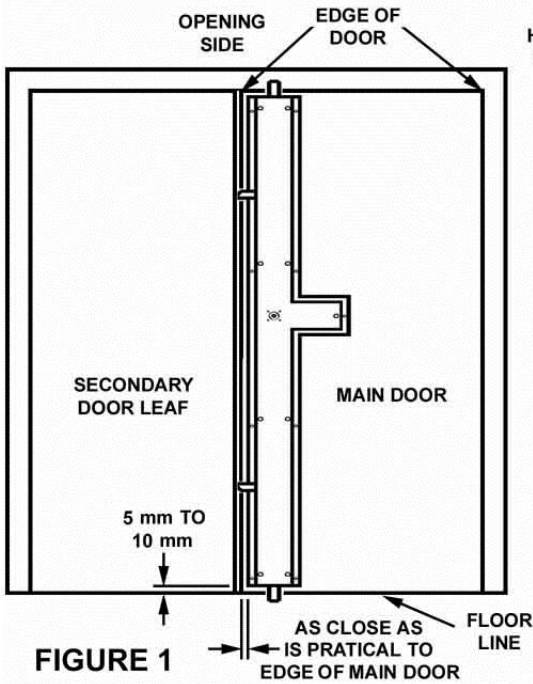

**FIGURE 1**

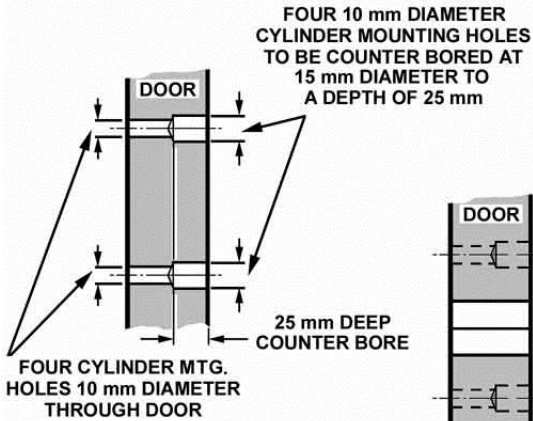

**FIGURE 4**  
TYPICAL SECTION FOR FOUR CYLINDER MOUNTING HOLES

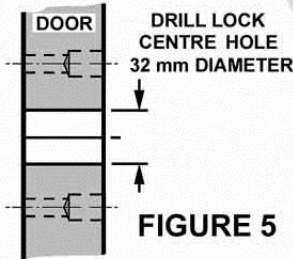

**FIGURE 5**

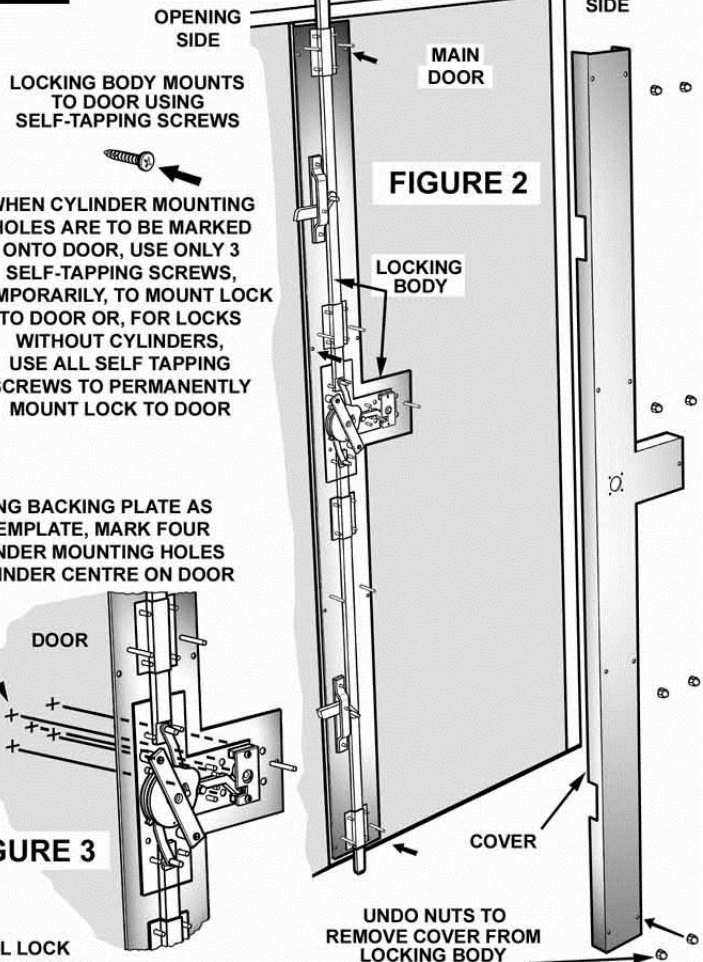

**FIGURE 2**

**FIGURE 3**

UNDO NUTS TO REMOVE COVER FROM LOCKING BODY

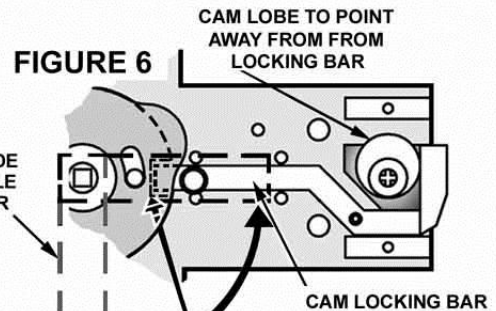

**FIGURE 6**

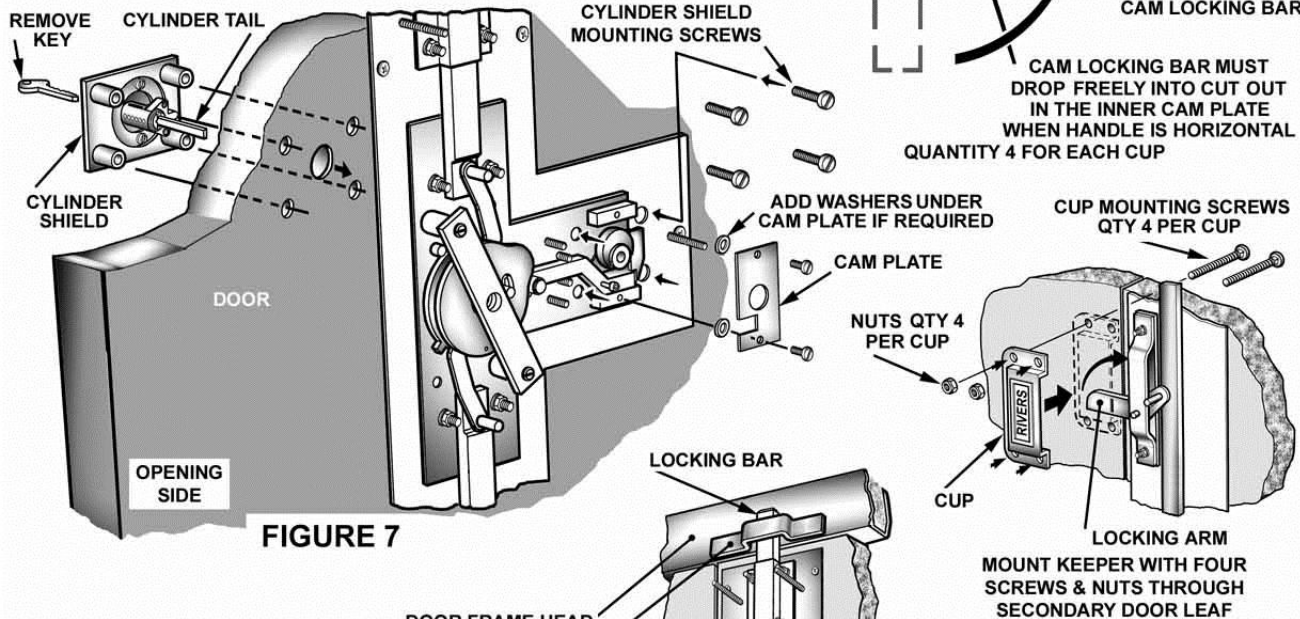

**FIGURE 7**

DOOR FRAME HEAD  
WELD KEEPER INTO  
POSITION ON DOOR FRAME

**FIGURE 8**

**FIGURE 9**